

MENIIT

NEET | IIT-JEE | FOUNDATION

Corporate Office: 44-A/1, Kalu Sarai, New Delhi 110016 | Web: www.meniit.com

JEE Advanced : Paper-1 (2011)

IMPORTANT INSTRUCTIONS

A. General:

1. The **question paper CODE** is printed on the right hand top corner of this sheet and on the back page (page no. 19) of this booklet.
2. No additional sheets will be provided for rough work.
3. Blank papers, clipboards, log tables, slide rules, calculators, cellular phones, pagers, and electronic gadgets in any form are not allowed.
4. Write your name and registration number in the space provided on the back page of this booklet.
5. The answer sheet, a machine-gradable Objective Response sheet (**ORS**), is provided separately.
6. **DO NOT TAMPER WITH /MUTILATE THE ORS OR THE BOOKLET.**
7. Do not break the seals of the question paper booklet before instructed to do so by the invigilators.
8. This question paper contains 19 pages having 69 questions.
9. On breaking the seals please check that all the questions are legible.

B. Filling the Right Part of the ORS:

10. The ORS also has a **CODES** printed on its lower and upper parts.
11. Make sure the **CODE** on the **ORS** is the same as that on this booklet. If the Codes do not match, ask **for a change of the Booklet.**
12. Write your Registration No., Name and Name of centre and sign with pen in appropriate boxes. Do not write these anywhere else. Darken the appropriate bubbles under each digit of your Registration No. with HB Pencil.

C. Question paper format and Marking scheme:

13. The question paper consists of **3 parts** (Chemistry, Physics and Mathematics). Each part consists of four sections.
14. In **Section I** (Total marks : 21), for each question you will be awarded 3 marks if you darken **ONLY** the bubble corresponding to the correct answer and **zero mark** if no bubbles are darkened. In all other cases, **minus one (-1) mark** will be awarded.
15. In **Section II** (Total Marks : 16), for each question you will be awarded 4 marks if you darken the bubble corresponding to the correct answer(s) **ONLY** and **zero mark** otherwise. There are **no negative marks** in this section.
16. In **Section III** (Total Marks : 15), for each question you will be **awarded 3 marks** if you darken **only** the bubble corresponding to the correct answer and **zero marks** if no bubble is darkened. In all other cases **minus one (-1) marks** will be awarded.
17. In **Section IV** (Total Marks : 28), for each question you will be **awarded 4 marks** if you darken **only** the bubble corresponding to the correct answer and **zero marks** otherwise. There are **no negative marks** in this section.

PART-A-CHEMISTRY

SECTION -I (Total Marks: 21)

(Single Correct Answer Type)

This section contains 7 multiple choice questions. Each question has four choices (A), (B), (C) and (D) out of which ONLY ONE is correct.

1. Among the following compounds, the most acidic is
 (A) p-nitrophenol (B) p-hydroxybenzoic acid
 (C) o-hydroxybenzoic acid (D) p-toluic acid

Ans. C

Sol. o-hydroxy benzoic acid is stronger acid due to ortho effect.

2. The major product of the following reaction is

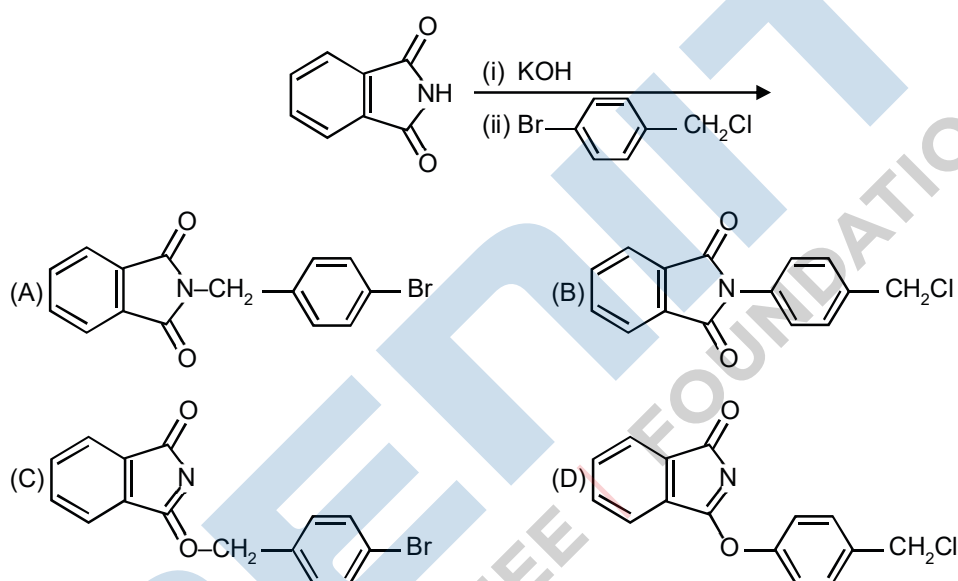

Ans. A

Sol.

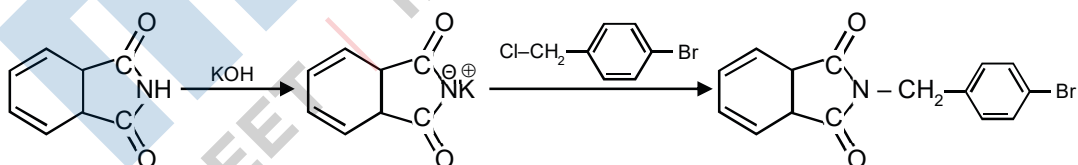

3. Extra pure N_2 can be obtained by heating
 (A) NH_3 with CuO (B) NH_4NO_3 (C) $(NH_4)_2Cr_2O_7$ (D) $Ba(N_3)_2$

Ans. D

Sol. $Ba(N_3)_2 \xrightarrow{\Delta} Ba + 3N_2 \uparrow$

4. Geometrical shapes of the complexes formed by the reaction of Ni^{2+} with Cl^- , CN^- and H_2O , respectively are
- (A) octahedral, tetrahedral and square planar
 (B) tetrahedral, square planar and octahedral
 (C) square planar, tetrahedral and octahedral
 (D) octahedral, square planar and tetrahedral

Ans. B

Sol. Complexes are : $[\text{NiCl}_4]^{-2}$, $[\text{Ni}(\text{CN})_4]^{-2}$ & $[\text{Ni}(\text{H}_2\text{O})_6]^{+2}$

$$\text{Ni}^{+2} = 3d^8 4s^0$$

$[\text{NiCl}_4]^{-2}$: Now Since, Cl^- is a weak legand so no pairing of electron take place and geometry is tetrahedral

$[\text{Ni}(\text{CN})_4]^{-2}$: Since, CN^- is a strong legand so pairing of electron will take place & geometry is square planar.

$[\text{Ni}(\text{H}_2\text{O})_6]^{+2}$: It will formed octahedral complex since C.N. = 6

5. Bombardment of aluminium by α -particle leads to its artificial disintegration in two way (i) and (ii) as shown. Products X, Y and Z respectively are,

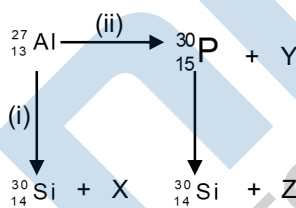

- (A) proton, neutron, positron
 (B) neutron, positron, proton
 (C) proton, positron, neutron
 (D) positron, proton, neutron

Ans. A

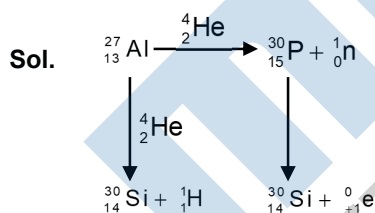

6. Dissolving 120 g of urea (mol. wt. 60) in 1000 g of water gave a solution of density 1.15 g/mL The molarity of the solution is
- (A) 1.78 M (B) 2.00 M (C) 2.05 M (D) 2.22 M

Ans. C

Sol. $M = \frac{x \times d \times 10}{\text{mol wt}} = \frac{10.7 \times 1.15 \times 10}{60} = 2.05 \text{ M}$ x= percentage by weight

$$x = \frac{120}{120 + 1000} \times 100$$

7. AgNO_3 (aq.) was added to an aqueous KCl solution gradually and the conductivity of the solution was measured. The plot of conductance (\wedge) versus the volume of AgNO_3 is

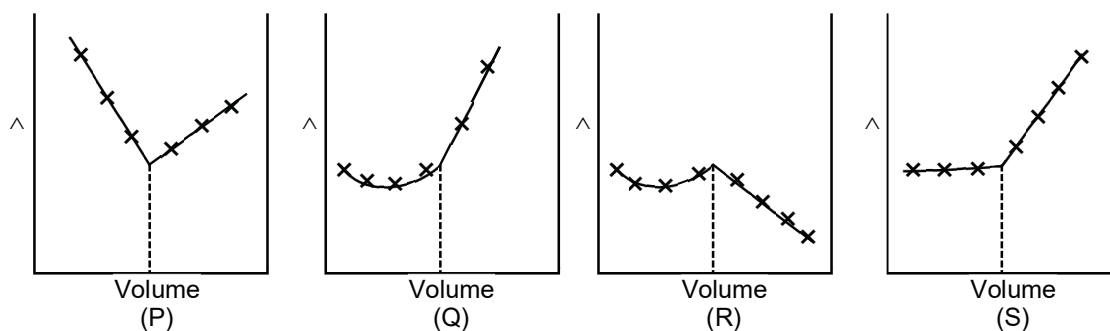

- (A) (P) (B) (Q) (C) (R) (D) (S)

Ans. D

Sol. Because in the beginning of the reaction no of ions remain constant so conductivity remains constant but after complete precipitation of Cl^- the no. of ions increases in solution. So conductivity increases.

SECTION -II (Total Marks : 16)

(Multiple Correct Answer Type)

This section contains 4 multiple choice questions. Each question has four choices (A), (B), (C) and (D) out of which ONE OR MORE may be correct.

8. The correct statement(s) pertaining to the adsorption of a gas on a solid surface is (are)
- (A) Adsorption is always exothermic
 (B) Physisorption may transform into chemisorption at high temperature
 (C) Physisorption increases with increasing temperature but chemisorption decreases with increasing temperature
 (D) Chemisorption is more exothermic than physisorption, however it is very slow due to higher energy of activation

Ans. B,D

Sol. Factual.

9. Extraction of metal from the ore **cassiterite** involves
- (A) carbon reduction of an oxide ore (B) self-reduction of a sulphide ore
 (C) removal of copper impurity (D) removal of iron impurity

Ans. A,C,D

Sol. Cassiterite is SnO_2 .

To reduce SnO_2 into Sn, carbon reduction process is used.

Sn has iron impurity.

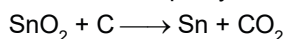

* The most appropriate answer to this question is (A,C,D), but because of ambiguity in language, IIT has declared (A, D) as correct answer

10. According to kinetic theory of gases
 (A) collisions are always elastic
 (B) heavier molecules transfer more momentum to the wall of the container
 (C) only a small number of molecules have very high velocity.
 (D) between collisions, the molecules move in straight lines with constant velocities.

Ans. A,B,C,D

Sol. Factual.

* The most appropriate answer to this question is (A, D), but because of ambiguity in language, IIT has declared (A,C,D) as correct answer

11. Amongst the given options, the compound(s) in which all the atoms are in one plane in all the possible conformations (if any), is (are)

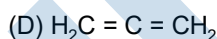
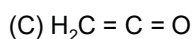
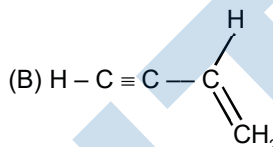
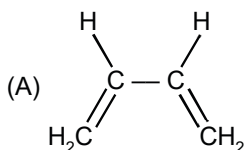

Ans. B,C

Sol. Factual.

SECTION - III (Total Marks : 15)

(Paragraph Type)

This section contains 2 paragraphs. Based upon the first paragraph 2 multiple choice questions and based upon the second paragraph 3 multiple choice questions have to be answered. Each of these questions has four choices (A), (B), (C) and (D) out of which ONLY ONE is correct.

Paragraph for Questions 12 to 13

An acyclic hydrocarbon P, having molecular formula C_6H_{10} , gave acetone as the only organic product through the following sequence of reactions, in which Q is an intermediate organic compound.

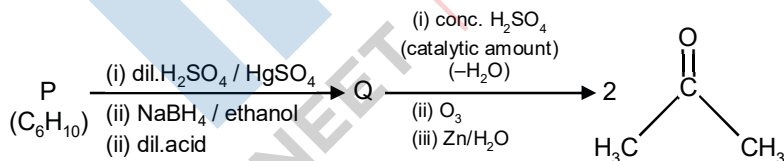

12. The structure of compound P is

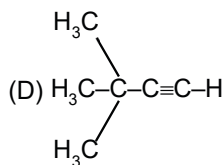
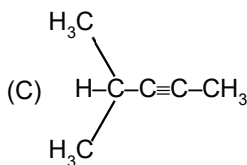
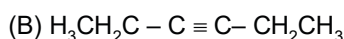
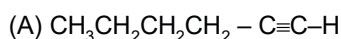

Ans. D

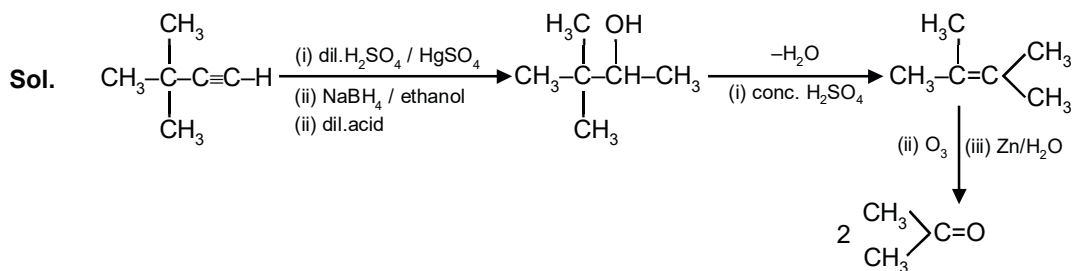

13. The structure of the compound Q is

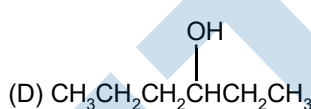
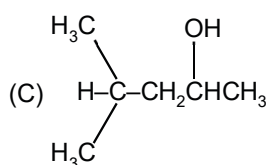
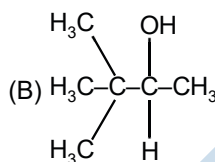
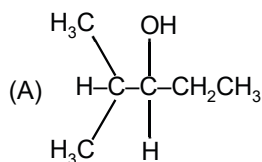

Ans. B

Sol. Factual.

Paragraph for Questions 14 to 16

When a metal rod **M** is dipped into an aqueous colourless concentrated solution of compound **N**, the solution turns light blue. Addition of aqueous NaCl to the blue solution gives a white precipitate **O**. Addition of aqueous NH₃ dissolves **O** gives an intense blue solution.

14. The metal rod **M** is

- (A) Fe (B) Cu (C) Ni (D) Co

Ans. B

Sol. Metal rod M is Cu

15. The compound **N** is

- (A) AgNO₃ (B) Zn(NO₃)₂ (C) Al(NO₃)₃ (D) Pb(NO₃)₂

Ans. A



16. The final solution contains

- (A) [Pb(NH₃)₄]²⁺ and [CoCl₄]²⁻ (B) [Al(NH₃)₄]³⁺ and [Cu(NH₃)₄]²⁺
(C) [Ag(NH₃)₂]⁺ and [Cu(NH₃)₄]²⁺ (D) [Ag(NH₃)₂]⁺ and [Ni(NH₃)₆]²⁺

Ans. C

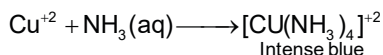
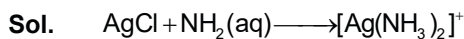

SECTION -IV (Total Marks : 28)

(Integer Answer Type)

This section contains 7 questions. The answer to each question is a single-digit integer, ranging from 0 to 9. The bubble corresponding to the correct answer is to be darkened in the ORS.

17. The total number of alkenes possible by dehydrobromination of 3-bromo-3-cyclopentylhexane using alcoholic KOH is :

Ans. 5

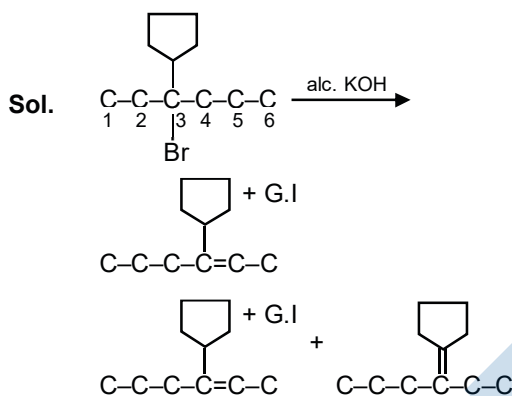

18. A decapeptide (Mol. Wt. 796) on complete hydrolysis gives glycine (Mol. Wt. 75), alanine and phenylalanine. Glycine contributes 47.0 % to the total weight of the hydrolysed products. The number of glycine units present in the decapeptide is :

Ans. 6

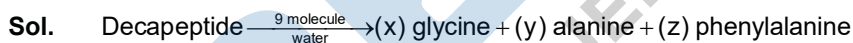

Mass of hydrolysed product = $796 + 18 \times 9$

mass of glycine = $958 \times \frac{47}{100} = 450.26$

No. of glycine unit = $\frac{450.26}{75} = 6$

19. To an evacuated vessel with movable piston under external pressure of 1 atm., 0.1 mol of He and 1.0 mol of an unknown compound (vapour pressure 0.68 atm, at 0°C) are introduced. Considering the ideal gas behaviour, the total volume (in litre) of the gases at 0°C is close to

Ans. 7

Sol.

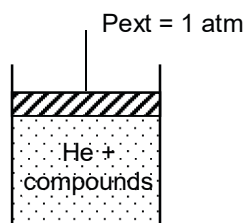

Vapour pressure of compound = 0.68

$\therefore P_{\text{He}} = 1 - 0.68 = 0.32$ \therefore By $PV = nRT$, for He

$$V = \frac{n_{\text{He}}RT}{P_{\text{He}}} = \frac{0.1 \times 0.0821 \times 273}{0.32}$$

$V \approx 7\text{L}$

20. The work function (ϕ) of some metals is listed below. The number of metals which will show photoelectric effect when light of 300 nm wavelength falls on the metal is

Metal	Li	Na	K	Mg	Cu	Ag	Fe	Pt	W
$\phi(\text{eV})$	2.4	2.3	2.2	3.7	4.8	4.3	4.7	6.3	4.75

Ans. 4

Sol. $E_{\text{falling}} = \frac{hc}{\lambda} = \frac{6.62 \times 10^{-34} \times 3 \times 10^8}{300 \times 10^{-9} \times 1.6 \times 10^{-19}} = 4.137 \text{ eV}$

The metals having less work function will show photoelectric effect

Hence Li, Na, K, Mg

21. The maximum number of electrons that can have principal quantum number, $n = 3$, and spin quantum number, $m_s = -\frac{1}{2}$, is :

Ans. 9

Sol. For $n = 3$, $\max e^- = 2n^2 = 18$
Half of them can have $m_s = -1/2$

22. Reaction of Br_2 with Na_2CO_3 in aqueous solution sodium bromide and sodium bromate with evolution of CO_2 gas. The number of sodium bromide molecules involved in the balanced chemical equation is

Ans. 5



23. The difference in the oxidation numbers of the two types of sulphur atoms in $\text{Na}_2\text{S}_4\text{O}_6$ is

Ans. 5

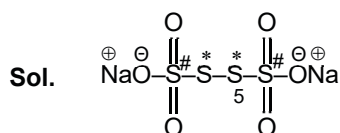

O.N. $\text{S}^* = 0$

O.N. $\text{S}\# = +5$

\therefore Difference = 5

PART B: PHYSICS

SECTION - I

Single Correct Choice Type

This section contains 7 multiple choice questions. Each question has four choices (A), (B), (C) and (D) out of which ONLY ONE is correct.

24. A meter bridge is set-up as shown, to determine an unknown resistance 'X' using a standard 10 ohm resistor. The galvanometer shows null point when tapping-key is at 52 cm mark. The end-corrections are 1 cm and 2 cm respectively for the ends A and B. The determined value of 'X' is

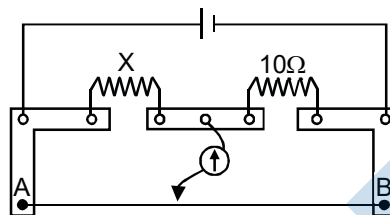

- (A) 10.2 ohm (B) 10.6 ohm (C) 10.8 ohm (D) 11.1 ohm

Ans. B

Sol.
$$\frac{x}{10} = \frac{52+1}{48+2}$$

$$= \frac{53 \times 10}{50} = 10.6$$

25. A $2\mu\text{F}$ capacitor is charged as shown in figure. The percentage of its stored energy dissipated after the switch S is turned to position 2 is

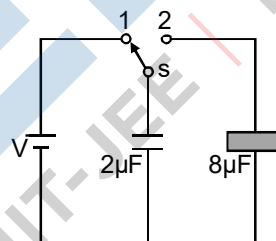

- (A) 0% (B) 20% (C) 75% (D) 80%

Ans. D

Sol.

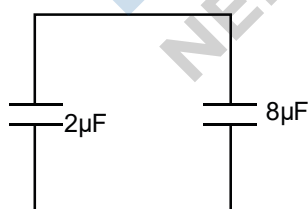

$$\Delta U = \frac{1}{2} \times \frac{2 \times 8}{2+8} [V - 0]^2$$

$$= \frac{1}{2} \times \frac{16}{10} V^2 = \frac{8V^2}{10}$$

$$U_i = \frac{1}{2} \times 2 \times V^2$$

$$= V^2$$

$$\% \text{ dissipated} = \frac{\Delta U}{U_i} = \frac{8}{10} \times 100$$

26. A police car with a siren of frequency 8 kHz is moving with uniform velocity 36 km/hr towards a tall building which reflects the sound waves. The speed of sound in air is 320 m/s. The frequency of the siren heard by the car driver is

(A) 8.50 kHz (B) 8.25 kHz (C) 7.75 kHz (D) 7.50 kHz

Ans. A

Sol. $V_s = \frac{36 \times 10^3}{3600} \text{ m/s} = 10 \text{ m/s}$, $v = 8 \text{ KHz}$

$$V_0 = 320 \text{ m/s}$$

$$V_0 = V_s = 10 \text{ m/s}$$

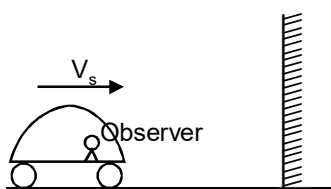

$$v' = \left(\frac{V + V_0}{V - V_s} \right) v$$

$$= \left(\frac{320 + 10}{320 - 10} \right) 8 \text{ KHz}$$

$$= \frac{330}{310} \times 8 = 8.51 \text{ KHz}$$

27. 5.6 liter of helium gas at STP is adiabatically compressed to 0.7 liter. Taking the initial temperature to be T_1 , the work done in the process is

(A) $\frac{9}{8} RT_1$ (B) $\frac{3}{2} RT_1$ (C) $\frac{15}{8} RT_1$ (D) $\frac{9}{2} RT_1$

Ans. A

Sol. $T_1 V_1^{\gamma-1} = T_2 V_2^{\gamma-1}$

$$T_2 = T_1 \left(\frac{V_1}{V_2} \right)^{\gamma-1}$$

$$= T_1 \left(\frac{5.6}{0.7} \right)^{\frac{5}{3}-1} = T_1 (8)^{2/3} = 4T_1$$

no. of mole = $\frac{1}{4}$

$$W = \frac{nR(T_1 - T_2)}{\gamma - 1} = \frac{\frac{1}{4} \times R(4T_1 - T_1)}{2/3} = \frac{9}{8}RT_1$$

28. Consider an electric field $\vec{E} = E_0 \hat{x}$, where E_0 is a constant. The flux through the shaded area (as shown in the figure) due to this field is :

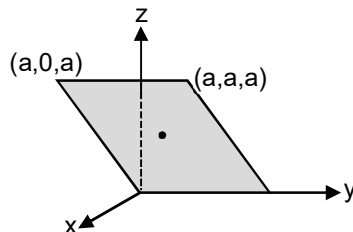

- (A) $2E_0a^2$ (B) $\sqrt{2}E_0a^2$ (C) E_0a^2 (D) $\frac{E_0a^2}{\sqrt{2}}$

Ans. C

Sol.

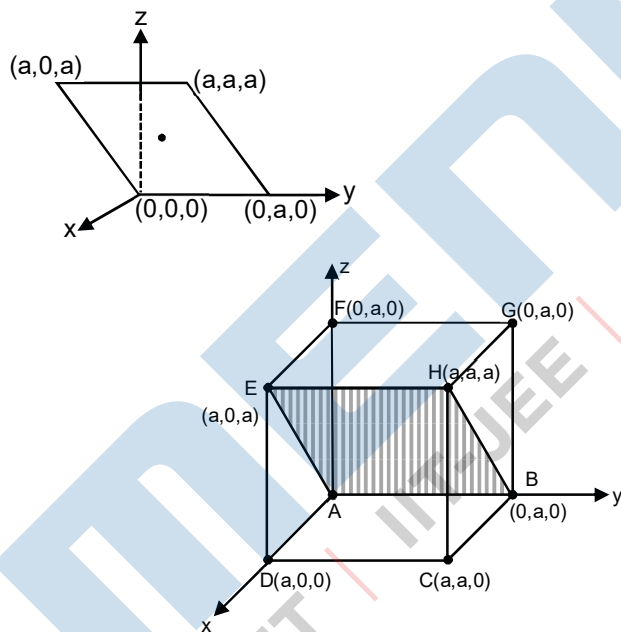

flux through EHBA
= flux through EHDC
= E_0a^2

29. The wavelength of the first spectral line in the Balmer series of hydrogen atom is 6561\AA . The wavelength of the second spectral line in the Balmer series of singly-ionized helium atom is
- (A) 1215\AA (B) 1640\AA (C) 2430\AA (D) 4687\AA

Ans. A

Sol. $\frac{hc}{6561} = 13.6 \left[\frac{1}{2^2} - \frac{1}{3^2} \right]$

$$\frac{hc}{\lambda} = 13.6 \times 4 \left[\frac{1}{2^2} - \frac{1}{4^2} \right]$$

$$\frac{hc}{6561} = 13.6 \times \frac{5}{36}$$

$$\frac{hc}{\lambda} = 13.6 \times 4 \times \frac{3}{16}$$

30. A ball of mass (m) 0.5 kg is attached to the end of a string having length (L) 0.5 m. The ball is rotated on a horizontal circular path about vertical axis. The maximum tension that the string can bear is 324 N. The maximum possible value of angular velocity of ball (in radian/s) is

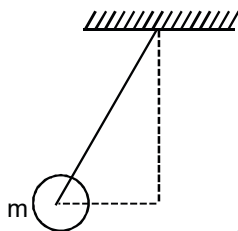

(A) 9

(B) 18

(C) 27

(D) 36

Ans. D

Sol.

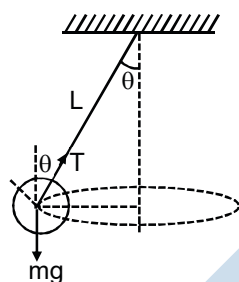

$$T \cos \theta = mg$$

$$T \sin \theta = m\omega^2 L \sin \theta$$

$$T = m\omega^2 L$$

$$\omega_{\max}^2 = \frac{T_{\max}}{mL}$$

$$\omega_{\max} = \sqrt{\frac{T_{\max}}{mL}} = \sqrt{\frac{324}{0.5 \times 0.5}} = \sqrt{324 \times 4}$$

$$= 36 \text{ rad/s}$$

SECTION -II

Multiple Correct Choice Type

This section contains 4 multiple choice questions. Each question has four choices (A), (B), (C) and (D) out of which ONE OR MORE may be correct.

31. An electron and a proton are moving on straight parallel paths with same velocity. They enter a semi-infinite region of uniform magnetic field perpendicular to the velocity. Which of the following statement(s) is/are true?
- (A) They will never come out of the magnetic field region.
 - (B) They will come out travelling along parallel paths.
 - (C) They will come out at the same time.
 - (D) They will come out at different times.

Ans. B,D

Sol.

$$evB = \frac{m_e v^2}{R_e} \quad \left| \quad evB = \frac{m_p v^2}{R_p} \right.$$

$$R_e = \frac{m_e v}{eB} \quad \left| \quad R_p = \frac{m_p v}{eB} \right.$$

$$\boxed{R_p > R_e}$$

$$T_e = \frac{\pi R_e}{v} = \frac{\pi m_e}{eB} \quad \Rightarrow \quad \boxed{T_p > T_e}$$

$$T_p = \frac{\pi m_p}{eB}$$

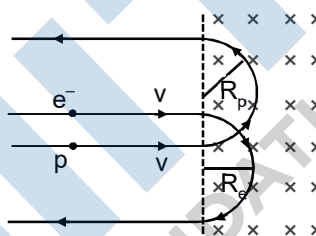

But as it's not mentioned that whether they entered in field together or not (C) and (D) could be right depending on data.

* The most appropriate answer to this question is (B,D), but because of ambiguity in language, IIT has declared [(B, C), (B, D), (B, C, D)] as correct answer

32. A spherical metal shell A of radius R_A and a solid metal sphere B of radius $R_B (< R_A)$ are kept far apart and each is given charge '+Q'. Now they are connected by a thin metal wire. Then

- (A) $E_A^{inside} = 0$
- (B) $Q_A > Q_B$
- (C) $\frac{\sigma_A}{\sigma_B} = \frac{R_B}{R_A}$
- (D) $E_A^{on\ surface} < E_B^{on\ surface}$

Ans. A,B,C,D

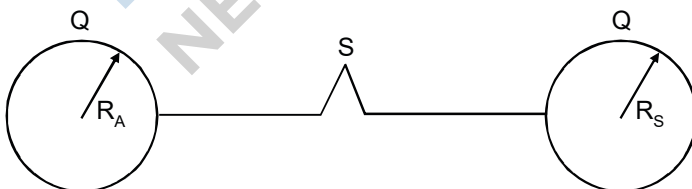

Sol.

$$\frac{kQ_A}{R_A} = \frac{kQ_B}{R_B} \quad \text{[Final potential will be same]}$$

Ans. (A)]

$$\frac{kQ_A}{R_A} = \frac{kQ_B}{R_B}$$

as $R_A > R_B$

$\therefore Q_A > Q_B$ Ans. [B]

$$\frac{\frac{Q_A}{4\pi R_A^2}}{\frac{Q_B}{4\pi R_B^2}} = \frac{\frac{R_A}{R_A^2}}{\frac{R_B}{R_B^2}} = \frac{\sigma_A}{\sigma_B} = \frac{R_B}{R_A} \text{ Ans. [C]}$$

as $R_A > R_B$

$\therefore \sigma_B > \sigma_A$

$\therefore E_B > E_A$ Ans. [D]

33. A composite block is made of slabs A, B, C, D and E of different thermal conductivity (given in terms of a constant K) and sizes (given in terms of length, L) as shown in the figure. All slabs are of same width. Heat 'Q' flows only from left to right through the blocks. Then in steady state

- (A) heat flow through A and E slabs are same
- (B) heat flow through slab E is maximum
- (C) temperature difference across slab E is smallest.
- (D) heat flow through C = heat flow through B + heat flow through D.

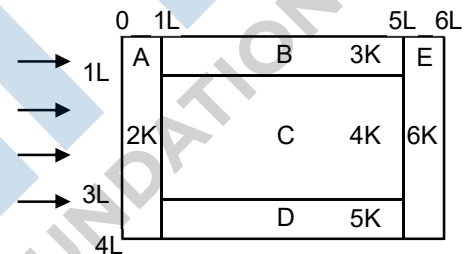

Ans. A,C,D

Sol.

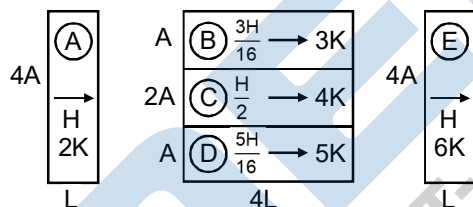

All the three system shown are in series hence rate of heat flow will be same through both A & E.

$$R_A = \frac{L}{8(KA)}; \quad R_B = \frac{4L}{3KA}; \quad R_C = \frac{4L}{8KA}; \quad R_D = \frac{4L}{5KA}; \quad R_E = \frac{L}{24KA}$$

Using parallel combination rate of heat flow across C = rate of heat flow through B + rate of heat flow through D.

$$\Delta\theta_A = HR_A = \frac{HL}{8KA}$$

$$\Delta\theta_B = \frac{3H}{16}R_B = \frac{3H}{16} \left(\frac{4L}{3KA} \right) = \frac{HL}{4KA}$$

$$\Delta\theta_C = \frac{H}{2}(R_C) = \frac{H}{2} \left(\frac{4L}{8KA} \right) = \frac{HL}{4KA}$$

$$\Delta\theta_D = \frac{5H}{16} \left(\frac{4L}{5KA} \right) = \frac{HL}{4KA}$$

$$\Delta\theta_E = H \left(\frac{L}{24KA} \right) = \frac{HL}{24KA}$$

34. A metal rod of length 'L' and mass 'm' is pivoted at one end. A thin disk of mass 'M' and radius 'R' (< L) is attached at its center to the free end of the rod. Consider two ways the disc is attached : (case A). The disc is not free to rotate about its center and (case B) the disc is free to rotate about its center. The rod-disc system performs SHM in vertical plane after being released from the same displacement position. Which of the following statement(s) is (are) true ?

- (A) Restoring torque in case A = Restoring torque in case B
- (B) Restoring torque in case A < Restoring torque in case B
- (C) Angular frequency for case A > Angular frequency for case B
- (D) Angular frequency for case A < Angular frequency for case B

Ans. A,D

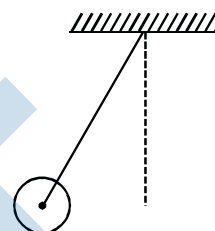

SECTION - III

Paragraph Type

This section contains 2 paragraphs. Based upon the first paragraph 2 multiple choice questions and based upon the second paragraph 3 multiple choice questions have to be answered. Each of these questions has four choices (A), (B), (C) and (D) out of which ONLY ONE is correct.

Paragraph for Questions 35 to 36

A dense collection of equal number of electrons and positive ions is called neutral plasma. Certain solids containing fixed positive ions surrounded by free electrons can be treated as neutral plasma. Let 'N' be the number density of free electrons, each of mass 'm'. When the electrons are subjected to an electric field, they are displaced relatively away from the heavy positive ions. If the electric field becomes zero, the electrons being to oscillate about the positive ions with a natural angular frequency ' ω_p ', which is called the plasma frequency. To sustain the oscillations, a time varying electric field needs to be applied that has an angular frequency ω , where a part of the energy is absorbed and a part of it is reflected. As ω approaches ω_p , all the free electrons are set to resonance together and all the energy is reflected. This is the explanation of high reflectivity of metals.

35. Taking the electronic charge as 'e' and the permittivity as ' ϵ_0 ', use dimensional analysis to determine the correct expression for ω_p .

- (A) $\sqrt{\frac{Ne}{m\epsilon_0}}$
- (B) $\sqrt{\frac{m\epsilon_0}{Ne}}$
- (C) $\sqrt{\frac{Ne^2}{m\epsilon_0}}$
- (D) $\sqrt{\frac{m\epsilon_0}{Ne^2}}$

Ans. C

Sol. $F = m\omega^2 \ell \equiv \frac{e^2}{4\pi\epsilon_0 \ell^2}$

$$\omega^2 \equiv \frac{e^2}{4\pi\epsilon_0\ell^3} \equiv \left(\frac{e}{m\epsilon_0}\right)\left(\frac{N\ell^3}{\ell^3}\right)$$

$$\omega = \sqrt{\frac{Ne^2}{m\epsilon_0}}$$

36. Estimate the wavelength at which plasma reflection will occur for a metal having the density of electrons $N \approx 4 \times 10^{27} \text{ m}^{-3}$. Take $\epsilon_0 \approx 10^{-11}$ and $m \approx 10^{-30}$, where these quantities are in proper SI units.

- (A) 800 nm (B) 600 nm (C) 300 nm (D) 200 nm

Ans. B

Sol. $c = \lambda f$

$$\omega_p = \omega = \frac{2\pi c}{\lambda} = \sqrt{\frac{Ne^2}{m\epsilon_0}}$$

$$\lambda = 2\pi c \sqrt{\frac{m\epsilon_0}{Ne^2}} = \frac{2\pi c}{e} \sqrt{\frac{m\epsilon_0}{N}} = \frac{2 \times 3.14 \times 10^8}{1.6 \times 10^{-19}} \sqrt{\frac{(10^{-30})(10^{-11})}{4 \times 10^{27}}}$$

$$= 589 \times 10^{-9} \text{ m} \approx 600 \text{ nm}$$

Paragraph for Questions 37 to 39

Phase space diagrams are useful tools in analyzing all kinds of dynamical problems. They are especially useful in studying the changes in motion as initial position and momentum are changed. Here we consider some simple dynamical systems in one-dimension. For such systems, phase space is a plane in which position is plotted along horizontal axis and momentum is plotted along vertical axis. The phase space diagram is $x(t)$ vs. $p(t)$ curve in this plane. The arrow on the curve indicates the time flow. For example, the phase space diagram for a particle moving with constant velocity is a straight line as shown in the figure. We use the sign convention in which position or momentum upwards (or to right) is positive and downwards (or to left) is negative.

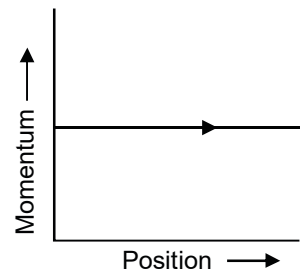

37. The phase space diagram for a ball thrown vertically up from ground is :

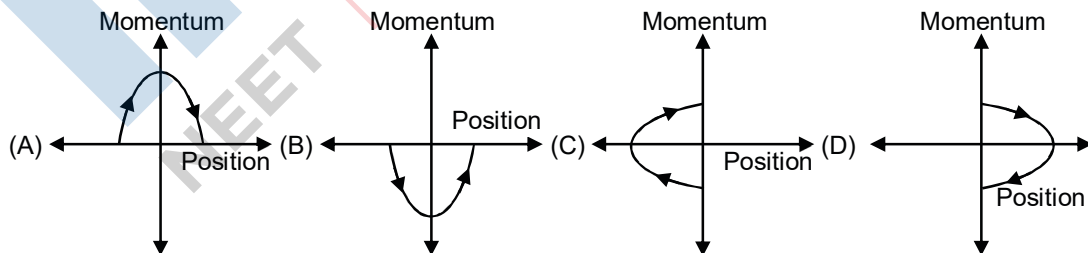

Ans. D

Sol. From conservation of mechanical energy

$$\frac{1}{2}mv^2 + mgx = \frac{1}{2}mu^2$$

$$m^2 v^2 - m^2 u^2 = 2m^2 gx$$

$$p^2 - p_0^2 = 2m^2 gx$$

$$p^2 = p_0^2 + 2m^2 gx$$

38. The phase space diagram for simple harmonic motion is a circle centered at the origin. In the figure, the two circles represent the same oscillator but for different initial conditions, and E_1 and E_2 are the total mechanical energies respectively. Then

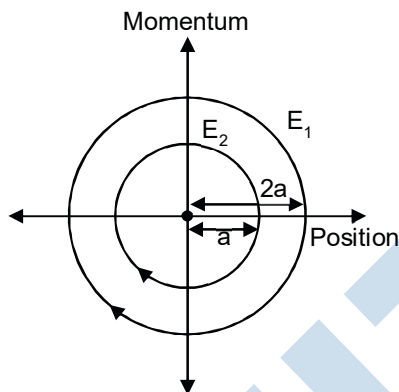

(A) $E_1 = \sqrt{2} E_2$

(B) $E_1 = 2 E_2$

(C) $E_1 = 4 E_2$

(D) $E_1 = 16 E_2$

Ans. C

Sol.

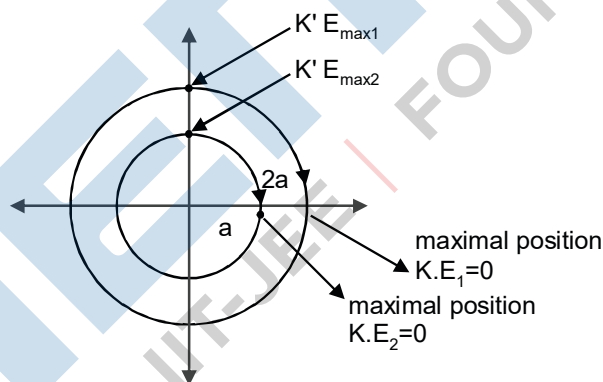

$$\frac{E_1}{E_2} = \frac{\frac{1}{2}k(2a)^2}{\frac{1}{2}k(a)^2} = 4$$

$$E_1 = 4E_2$$

39. Consider the spring-mass system, with the mass submerged in water, as shown in the figure. The phase diagram for one cycle of this system is :

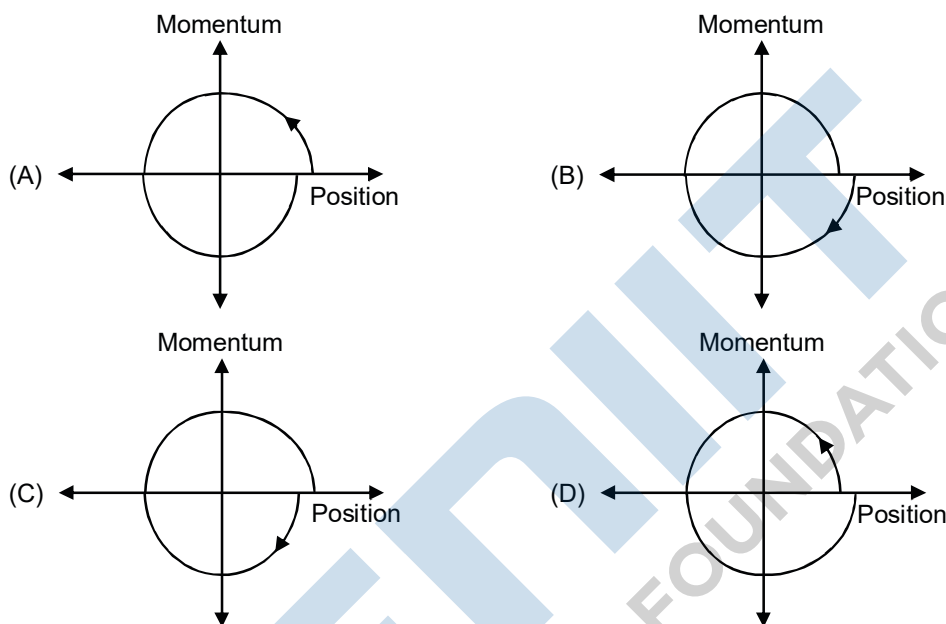
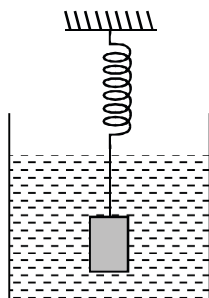

Ans. B

SECTION-IV

Integer Type

This section contains 7 questions. The answer to each question is a single-digit integer, ranging from 0 to 9. The correct digit below the question number in the ORS is to be bubbled.

40. A long circular tube of length 10 m and radius 0.3 m carries a current I along its curved surface as shown. A wire-loop of resistance 0.005 ohm and of radius 0.1 m is placed inside the tube with its axis coinciding with the axis of the tube. The current varies as $I = I_0 \cos(300 t)$ where I_0 is constant. If the magnetic moment of the loop is $N \mu_0 I_0 \sin(300 t)$, then 'N' is

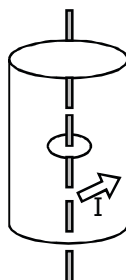

Ans. 6

Sol. $B = \frac{\mu_0 I_0 \cos 300t}{10}$

$$\phi = \frac{\mu_0 I_0}{10} \times 3.14 \times 0.01 \cos 300t$$

$$\phi = 3.14 \times \mu_0 I_0 \cos 300t \times 10^{-3}$$

$$e = -\frac{d\phi}{dt} = 3.14 \times 300 \mu_0 I_0 \sin 300t \times 10^{-3}$$

$$i = \frac{e}{R} = \frac{3.14 \times 300 \mu_0 I_0 \sin 300t \times 10^{-3}}{0.005}$$

$$i = 3.14 \times 60 \mu_0 I_0 \sin 300t$$

Magnetic moment

41. Four solid spheres each of diameter $\sqrt{5}$ cm and mass 0.5 kg are placed with their centres at the corners of a square of side 4 cm. The moment of inertia of the system about the diagonal of the square is $N \times 10^{-4}$ kg-m², then N is

Ans. 9

Sol. $r = \frac{\sqrt{5}}{2}$ cm = $\frac{\sqrt{5}}{2} \times 10^{-2}$ m

$$m = \frac{1}{2}$$
 kg

$$\ell = 4 \times 10^{-2}$$
 m

Using parallel axis theorem

$$I_{\text{total}} = \left[4 \times \frac{2}{5} \times \frac{1}{2} \times \frac{5}{4} \times 10^{-4} \right] + \left[2 \times \frac{1}{2} \times 8 \times 10^{-4} \right]$$

$$\Rightarrow 10^{-4} + 8 \times 10^{-4} \Rightarrow 9 \times 10^{-4} \text{ kg m}^2$$

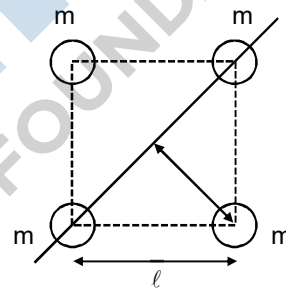

42. The activity of a freshly prepared radioactive sample is 10^{10} disintegrations per second whose mean life is 10^9 s. The mass of an atom of this radioisotope is 10^{-25} kg. The mass (in mg) of the radioactive sample is

Ans. 1

Sol. $A = \lambda N$

$$10^{10} = \frac{1}{10^9} N$$

$$N = 10^{19}$$

$$\text{Mass of sample} = 10^{19} \times 10^{-25} \times 1 \times 10^6 = 1 \text{ mg}$$

43. Steel wire of length 'L' at 40°C is suspended from the ceiling and then a mass 'm' is hung from its free end. The wire is cooled down from 40°C to 30°C to regain its original length 'L'. The coefficient of linear thermal expansion of the steel is $10^{-5} / ^\circ\text{C}$. Young's modulus of steel is 10^{11} N/m^2 and radius of the wire is 1 mm. Assume that $L \gg$ diameter of the wire. Then the value of 'm' in kg is nearly.

Ans. 3

Sol.
$$\Delta L = \frac{mgL}{AY} = L\alpha(\Delta\theta)$$

$$\Rightarrow m = \frac{AY\alpha(\Delta\theta)}{g} = \frac{\pi \times 10^{-6} \times 10^{11} \times 10^{-5} \times 10}{10}$$

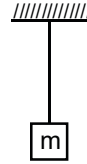

$m = 3.14 \text{ kg} \Rightarrow 3 \text{ kg}$

44. Four point charges, each of +q are rigidly fixed at the four corners of a square planar soap film of side 'a'. The surface tension of the soap film is γ . The system of charges and planar film are in equilibrium, and

$a = k \left[\frac{q^2}{\gamma} \right]^{1/N}$, where 'k' is a constant. Then N is

Ans. 3

Sol. $F_{AC} = \frac{q^2}{8\pi\epsilon_0 a^2}$

$F_{AD} = F_{AB} = \frac{q^2}{4\pi\epsilon_0 a^2}$

$F_R = \frac{q^2}{4\pi\epsilon_0 a^2} \left(2\cos 45^\circ + \frac{1}{2} \right)$
 $= r (2) (BD) = 2r(\sqrt{2} a)$

$\Rightarrow a^3 = \frac{q^2 \left(\sqrt{2} + \frac{1}{2} \right)}{8\sqrt{2}\pi\epsilon_0 r}$

$a = k \left(\frac{q^2}{r} \right)^{1/3} \Rightarrow N = 3$

Where $k = \left(\frac{\sqrt{2} + \frac{1}{2}}{8\sqrt{2}\pi} \right)^{1/3}$

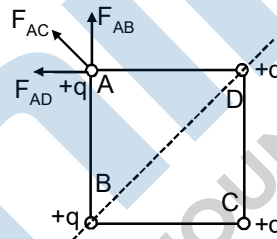

45. A block is moving on an inclined plane making an angle 45° with the horizontal and the coefficient of friction is μ . The force required to just push it up the inclined plane is 3 times the force required to just prevent it from sliding down. If we define $N = 10 \mu$, then N is

Ans. 5

46. A boy is pushing a ring of mass 2 kg and radius 0.5 m with a stick as shown in the figure. The stick applies a force of 2 N on the ring and rolls it without slipping with an acceleration of 0.3 m/s^2 . The coefficient of friction between the ground and the ring is large enough that rolling always occurs and the coefficient of friction between the stick and the ring is $\left(\frac{P}{10}\right)$. The value of P is :

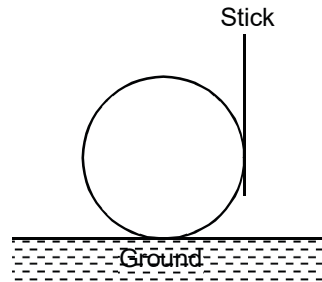

Ans. 4

Sol. $2 - f_2 = Ma_{cm}$ (1)

$$f_2 = 2 - 2 \times 0.3 = 1.4 \text{ N}$$

$$(f_2 - f_1) R = I_{cm} \alpha$$

$$(f_2 - f_1) R = MR^2 \times \frac{a_{cm}}{R}$$

$$f_2 - f_1 = Ma_{cm}$$

$$f_1 = f_2 - ma_{cm} = 1.4 - 2 \times 0.3 = 0.8 \text{ N}$$

$$0.8 = \frac{P}{5} \Rightarrow P = 4$$

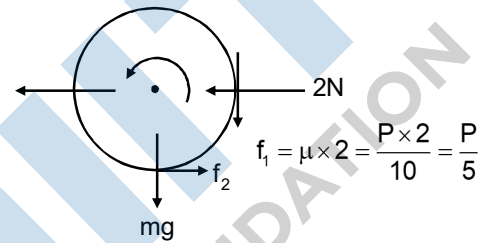

Note : It has been assumed that the stick applies horizontal force of 2N (only normal reaction)

PART C: MATHEMATICS

Section - I (Total Marks : 21)

(Single Correct Answer Type)

This section contains **7 multiple choice questions**. Each question has four choice (A), (B), (C) and (D) out of which **ONLY ONE** is correct.

- 47.** Let α and β be the roots of $x^2 - 6x - 2 = 0$, with $\alpha > \beta$. If $a_n = \alpha^n - \beta^n$ for $n \geq 1$, then the value of $\frac{a_{10} - 2a_8}{2a_9}$ is :
- (A) 1 (B) 2 (C) 3 (D) 4

Ans. C

Sol. $\therefore x^2 - 6x - 2 = 0$ has roots α, β

So, $a_2 - 2 = 6\alpha$ & $\beta^2 - 2 = 6\beta$

$$a_n = \alpha^n - \beta^n$$

So, $\frac{a_{10} - 2a_8}{2a_9} = \frac{(\alpha^{10} - \beta^{10}) - 2(\alpha^8 - \beta^8)}{2(\alpha^9 - \beta^9)} = \frac{\alpha^8(\alpha^2 - 2) - \beta^8(\beta^2 - 2)}{2(\alpha^9 - \beta^9)} = \frac{\alpha^8(6\alpha) - \beta^8(6\beta)}{2(\alpha^9 - \beta^9)} = 3.$

- 48.** A straight line L through the point $(3, -2)$ is inclined at an angle 60° to the line $\sqrt{3}x + y = 1$. If L also intersects the x-axis, then the equation of L is :

- (A) $y + \sqrt{3}x + 2 - 3\sqrt{3} = 0$ (B) $y - \sqrt{3}x + 2 + 3\sqrt{3} = 0$
 (C) $\sqrt{3}y - x + 3 + 2\sqrt{3} = 0$ (D) $\sqrt{3}y + x - 3 + 2\sqrt{3} = 0$

Ans. B

Sol. Let the slope of the line is m

$$\tan 60^\circ = \frac{|m + \sqrt{3}|}{|1 - \sqrt{3}m|}$$

$$\sqrt{3} = \frac{|m + \sqrt{3}|}{|1 - \sqrt{3}m|}$$

So, $m + \sqrt{3} = \pm\sqrt{3}(1 - \sqrt{3}m)$

$m + \sqrt{3} = \sqrt{3} - 3m$	$m + \sqrt{3} = -\sqrt{3} + 3m$
--------------------------------	---------------------------------

$m = 0$	$m = \sqrt{3}$
---------	----------------

hence line	hence line
------------	------------

$y = -2$	$y + 2 = \sqrt{3}(x - 3)$
----------	---------------------------

$y - \sqrt{3}x + 2 + 3\sqrt{3} = 0$

As line intersects x-axis

So line will be, $y - \sqrt{3}x + 2 + 3\sqrt{3} = 0$

49. Let (x_0, y_0) be the solution of the following equations

$$(2x)^{\ln 2} = (3y)^{\ln 3}$$

$$3^{\ln x} = 2^{\ln y}$$

Then x_0 is

(A) $\frac{1}{6}$

(B) $\frac{1}{3}$

(C) $\frac{1}{2}$

(D) 6

Ans. C

Sol. $(2x)^{\ln 2} = (3y)^{\ln 3}$

$$\ln 2 (\ln 2 + \ln x) = \ln 3 (\ln 3 + \ln y)$$

$$\ln 2 \cdot \ln x - \ln 3 \ln y = (\ln 3)^2 - (\ln 2)^2 \quad \dots(1)$$

$$3^{\ln x} = 2^{\ln y}$$

$$\ln x \cdot \ln 3 = \ln y \cdot \ln 2$$

$$\ln y = \ln x \cdot \frac{\ln 3}{\ln 2} \quad \dots(2)$$

Solving (1) & (2)

$$\ln x = -\ln 2 \Rightarrow x = \frac{1}{2}$$

50. The value of $\int_{\sqrt{\ln 2}}^{\sqrt{\ln 3}} \frac{x \sin x^2}{\sin x^2 + \sin(\ln 6 - x^2)} dx$ is :

(A) $\frac{1}{4} \ln \frac{3}{2}$

(B) $\frac{1}{2} \ln \frac{3}{2}$

(C) $\ln \frac{3}{2}$

(D) $\frac{1}{6} \ln \frac{3}{2}$

Ans. A

Sol. Let $x^2 = t \Rightarrow x dx = \frac{dt}{2}$

$$I = \frac{1}{2} \int_{\ln 2}^{\ln 3} \frac{\sin t}{\sin t + \sin(\ln 6 - t)} dt \quad \dots(1)$$

$$I = \frac{1}{2} \int_{\ln 2}^{\ln 3} \frac{\sin(\ln 6 - t)}{\sin t + \sin(\ln 6 - t)} dt \quad \dots(2)$$

Add (1) & (2)

$$2I = \frac{1}{2} \int_{\ln 2}^{\ln 3} dt$$

$$I = \frac{1}{4} (\ln 3 - \ln 2) = \frac{1}{4} \ln \frac{3}{2}$$

51. Let $\vec{a} = \hat{i} + \hat{j} + \hat{k}$, $\vec{b} = \hat{i} - \hat{j} + \hat{k}$ and $\vec{c} = \hat{i} - \hat{j} - \hat{k}$ be three vectors. A vector \vec{V} in the plane of \vec{a} and \vec{b} , whose projection on \vec{c} is $\frac{1}{\sqrt{3}}$, is given by

- (A) $\hat{i} - 3\hat{j} + 3\hat{k}$ (B) $-3\hat{i} - 3\hat{j} - \hat{k}$ (C) $3\hat{i} - \hat{j} + 3\hat{k}$ (D) $\hat{i} + 3\hat{j} - 3\hat{k}$

Ans. C

Sol. Let $\vec{v} = x\hat{i} + y\hat{j} + z\hat{k}$

$$\therefore [\vec{a} \ \vec{b} \ \vec{v}] = 0$$

$$\begin{vmatrix} 1 & 1 & 1 \\ 1 & -1 & 1 \\ x & y & z \end{vmatrix} = 0$$

On solving $x = z$ (1)

\therefore projection of \vec{v} on \vec{c} is $\frac{1}{\sqrt{3}}$

So, $\frac{1}{\sqrt{3}} = \frac{\vec{v} \cdot \vec{c}}{|\vec{c}|} \Rightarrow \frac{x - y - z}{\sqrt{3}} = \frac{1}{\sqrt{3}}$

$\Rightarrow x - y - z = 1$ (2)

So solving (1) & (2)

$y = -1$ & $x = z$

52. Let $P = \{\theta : \sin \theta - \cos \theta = \sqrt{2} \cos \theta\}$ and $Q = \{\theta : \sin \theta + \cos \theta = \sqrt{2} \sin \theta\}$ be two sets. Then

- (A) $P \subset Q$ and $Q - P \neq \phi$ (B) $Q \subset P$
 (C) $P \not\subset Q$ (D) $P = Q$

Ans. D

Sol. $P : \sin \theta - \cos \theta = \sqrt{2} \cos \theta$

$$\sin \theta = (\sqrt{2} + 1) \cos \theta$$

$$\tan \theta = \sqrt{2} + 1$$

$$\tan \theta = \tan 67\frac{1}{2}^\circ$$

$$\theta = n\pi + \frac{3\pi}{8}, n \in I \quad \dots\dots(1)$$

$Q : \sin \theta + \cos \theta = \sqrt{2} \sin \theta$

$$\cos \theta = (\sqrt{2} - 1) \sin \theta$$

$$\tan \theta = \frac{1}{\sqrt{2} - 1} = \sqrt{2} + 1$$

$$\theta = n\pi + \frac{3\pi}{8}, n \in I \quad \dots\dots(2)$$

$\therefore P = Q$

53. Let the straight line $x = b$ divide the area enclosed by $y = (1 - x)^2$, $y = 0$ and $x = 0$ into two parts R_1 ($0 \leq x \leq b$) and R_2 ($b \leq x \leq 1$) such that $R_1 - R_2 = \frac{1}{4}$. Then b equals

- (A) $\frac{3}{4}$ (B) $\frac{1}{2}$ (C) $\frac{1}{3}$ (D) $\frac{1}{4}$

Ans. B

Sol. $R_1 - R_2 = \frac{1}{4}$

$$\int_0^b (x-1)^2 dx - \int_b^1 (x-1)^2 dx = \frac{1}{4}$$

$$\left[\frac{(x-1)^3}{3} \right]_0^b - \left[\frac{(x-1)^3}{3} \right]_b^1 = \frac{1}{4}$$

$$\frac{(b-1)^3}{3} + \frac{1}{3} - 0 + \frac{(b-1)^3}{3} = \frac{1}{4}$$

$$\frac{2(b-1)^3}{3} = \frac{1}{4} - \frac{1}{3} = \frac{-1}{12}$$

$$(b-1)^3 = -\frac{1}{8}$$

$$b-1 = -\frac{1}{8} \Rightarrow b = \frac{1}{2}$$

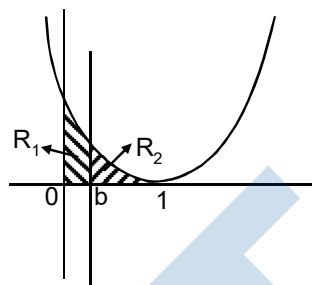

Section - II (Total Marks : 16)

(Multiple Correct Answer Type)

This section contains 4 multiple choice questions. Each question has four choice (A), (B), (C) and (D) out of which ONE or MORE may be correct.

54. Let M and N be two 3×3 non-singular skew-symmetric matrices such that $MN = NM$. If P^T denotes the transpose of P , then $M^2 N^2 (M^T N)^{-1} (MN^{-1})^T$ is equal to :

- (A) M^2 (B) $-N^2$ (C) $-M^2$ (D) MN

Ans. C

Sol. $\because MN = NM$

$$M^2 N^2 = MN MN \quad \because (M^T)^{-1} = (-M)^{-1} = -M^{-1}$$

Given, $M^2 N^2 (M^T N)^{-1} \cdot (MN^{-1})^T$

$$= -MN \underbrace{MN N^{-1} M^{-1} N^{-1}}_I M$$

$$= -M NN^{-1} M = -M^2$$

Although, the most suitable answer is (C), But given information is contradictory as Skew symmetric matrix of odd order cannot be non singular

* The most appropriate answer to this question is (C), but because of ambiguity in language, IIT has declared this question as bonus (marks to all students)

55. The vector(s) which is/are coplanar with vectors $\hat{i} + \hat{j} + 2\hat{k}$ and $\hat{i} + 2\hat{j} + \hat{k}$ and perpendicular to the vector $\hat{i} + \hat{j} + \hat{k}$ is/are

- (A) $\hat{j} - \hat{k}$ (B) $-\hat{i} + \hat{j}$ (C) $\hat{i} - \hat{j}$ (D) $-\hat{j} + \hat{k}$

Ans. A,D

Sol. $\vec{r} = x\hat{i} + y\hat{j} + z\hat{k}$ is coplanar with the given vector so

$$\therefore \begin{vmatrix} x & y & z \\ 1 & 1 & 2 \\ 1 & 2 & 1 \end{vmatrix} = 0$$

So, $3x = y + z$ (1)

$\therefore \vec{r} \perp \hat{i} + \hat{j} + \hat{k}$

So, $\vec{r} \cdot (\hat{i} + \hat{j} + \hat{k}) = 0$

So, $x + y + z = 0$ (2)

On solving (1) & (2)

So, $x = 0$ $\therefore y + z = 0$ \therefore (A) & (D) Satisfy

56. Let the eccentricity of the hyperbola $\frac{x^2}{a^2} - \frac{y^2}{b^2} = 1$ be reciprocal to that of the ellipse $x^2 + 4y^2 = 4$. If the hyperbola passes through a focus of the ellipse, then

(A) the equation of the hyperbola is $\frac{x^2}{3} - \frac{y^2}{2} = 1$.

(B) a focus of the hyperbola is (2, 0).

(C) the eccentricity of the hyperbola is $\sqrt{\frac{5}{3}}$.

(D) the equation of the hyperbola is $x^2 - 3y^2 = 3$.

Ans. B,D

Sol. Let e_1 = eccentricity of hyperbola

e_2 = eccentricity of ellipse

$\therefore e_1 = \frac{1}{e_2}$

So, eccentricity of ellipse = $\frac{\sqrt{3}}{2} = e_2$

eccentricity of ellipse = $\frac{\sqrt{3}}{2} = e_1$

Now focus of ellipse is $(\pm ae_2, 0) \equiv (\pm \sqrt{3}, 0)$

Hyperbola passes through it

$$\text{So, } \frac{(\sqrt{3})^2}{a^2} - 0 = 1 \Rightarrow a^2 = 3$$

$$\text{also } b^2 = a^2 (e_1^2 - 1)$$

$$b^2 = 3 \left(\frac{4}{3} - 1 \right) = 1$$

and hyperbola

$$\frac{x^2}{3} - \frac{y^2}{1} = 1$$

also focus $(\pm ae_1, 0) \equiv (\pm 2, 0)$

57. Let $f : \mathbb{R} \rightarrow \mathbb{R}$ be a function such that

$$f(x + y) = f(x) + f(y), \quad \forall x, y \in \mathbb{R}.$$

If $f(x)$ is differentiable at $x = 0$, then

- (A) $f(x)$ is differentiable only in a finite interval containing zero.
- (B) $f(x)$ is continuous $\forall x \in \mathbb{R}$.
- (C) $f'(x)$ is constant $\forall x \in \mathbb{R}$.
- (D) $f(x)$ is differentiable except at finitely many points.

Ans. B,C

Sol. $f(x + y) = f(x) + f(y)$

By Partial differentiation with respect to x

$$f'(x + y) = f'(x)$$

$$f'(y) = f'(0)$$

$$f(y) = (f'(0))y + c$$

$$f(y) = ky + c$$

$$\therefore f(y) = ky \quad \text{as } f(0) = 0$$

$$\therefore f(x) = kx$$

Alternate

$$\begin{aligned} f'(x) &= \lim_{h \rightarrow 0} \frac{f(x+h) - f(x)}{h} \\ &= \lim_{h \rightarrow 0} \frac{f(x) + f(h) - f(x)}{h} = \lim_{h \rightarrow 0} \frac{f(h)}{h} \\ &= \lambda \text{ (let)} \end{aligned}$$

$$f(x) = \lambda x + c \text{ As } f(0) = 0 \Rightarrow c = 0$$

$$f(x) = \lambda x$$

- * The most appropriate answer to this question is (B, C), but because of ambiguity in language, IIT has declared (BC,BCD) as correct answer.

Section - III (Total Marks : 15)

(Paragraph Type)

This section contains **2 paragraphs**. Based upon one of the paragraphs **2 multiple choice questions** and based on the other paragraph **3 multiple choice questions** have to be answered. Each question has four choice (A), (B), (C) and (D) out of which **ONLY ONE** is correct.

Paragraph for Question Nos. 58 and 59

Let U_1 and U_2 be two urns such that U_1 contains 3 white and 2 red balls, and U_2 contains only 1 white ball. A fair coin is tossed. If head appears then 1 ball is drawn at random from U_1 and put into U_2 . However, if tail appears then 2 balls are drawn at random from U_1 and put into U_2 . Now 1 ball is drawn at random from U_2 .

58. The probability of the drawn ball from U_2 being white is

- (A) $\frac{13}{30}$ (B) $\frac{23}{30}$ (C) $\frac{19}{30}$ (D) $\frac{11}{30}$

Ans. B

Sol. $\begin{matrix} \boxed{3W} \\ \boxed{2R} \\ U_1 \end{matrix}$ $\begin{matrix} \boxed{1W} \\ U_2 \end{matrix}$

Required probability = $P(H)[P(W/H) \times P(W_2) + P(R/H)P(W_2)] + P(T) [P\left(\frac{\text{bothW}}{T}\right) P(W_2) + P\left(\frac{\text{bothR}}{T}\right) P(W_2) + P\left(\frac{R_1 \& W_1}{T}\right) P(W_2)]$

$$= \frac{1}{2} \left[\frac{3}{5} \times 1 + \frac{2}{5} \times \frac{1}{2} \right] + \frac{1}{2} \left[\frac{{}^3C_2 \times 1}{{}^5C_2} + \frac{{}^2C_2 \times \frac{1}{3} + \frac{{}^3C_2 \times {}^3C_2 \times \frac{2}{3}}{{}^5C_2}} \right]$$

$$= \frac{1}{2} \left[\frac{3}{5} + \frac{1}{5} \right] + \frac{1}{2} \left[\frac{3}{10} + \frac{1}{30} + \frac{2}{5} \right] = \frac{2}{5} + \frac{11}{30} = \frac{23}{30}$$

59. Given that the drawn ball from U_2 is white, the probability that head appeared on the coin is :

- (A) $\frac{17}{23}$ (B) $\frac{11}{23}$ (C) $\frac{15}{23}$ (D) $\frac{12}{23}$

Ans. D

Sol. Required probability

$$= \frac{P(H) \left[P\left(\frac{W_1}{H}\right) P(W_2) + P\left(\frac{R_1}{H}\right) P(W_2) \right]}{P(H) \left[P\left(\frac{W_1}{H}\right) P(W_2) + P\left(\frac{R_1}{H}\right) P(W_2) \right] + P(T) \left[P\left(\frac{\text{bothW}}{T}\right) P(W_2) + P\left(\frac{\text{bothR}}{T}\right) P(W_2) + P\left(\frac{R_1 \& W_1}{T}\right) P(W_2) \right]}$$

$$= \frac{\frac{1}{2} \left[\frac{3}{5} \times 1 + \frac{2}{5} \times \frac{1}{2} \right]}{\frac{23}{30}} = \frac{12}{13}$$

Paragraph for Question Nos. 60 and 62

Let a, b and c be three real numbers satisfying

$$[a \ b \ c] \begin{bmatrix} 1 & 9 & 7 \\ 8 & 2 & 7 \\ 7 & 3 & 7 \end{bmatrix} = [0 \ 0 \ 0] \quad \dots\dots(E)$$

- 60.** If the point P(a, b, c), with reference to (E), lies on the plane $2x + y + z = 1$, then the value of $7a + b + c$, is
 (A) 0 (B) 12 (C) 7 (D) 6

Ans. D

Sol. $[a \ b \ c] \begin{bmatrix} 1 & 9 & 7 \\ 8 & 2 & 7 \\ 7 & 3 & 7 \end{bmatrix} = [0 \ 0 \ 0]$

$$a + 8b + 7c = 0$$

$$9a + 2b + 3c = 0$$

$$7a + 7b + 7c = 0$$

On solving above equation

$$(a, b, c) \equiv \left(-\frac{\lambda}{7}, -\frac{6\lambda}{7}, \lambda \right)$$

\therefore (a, b, c) lies on the plane $2x + y + z = 1$

$$\text{So } -\frac{2\lambda}{7} - \frac{6\lambda}{7} + \lambda = 0$$

on solving $\lambda = -7$

$$\text{So } 7a + b + c = 6$$

- 61.** Let ω be a solution of $x^3 - 1 = 0$ with $\text{Im}(\omega) > 0$. If $a = 2$ with b and c satisfying (E), then the value of $\frac{3}{\omega^a} + \frac{1}{\omega^b} + \frac{3}{\omega^c}$ is equal to :
 (A) -2 (B) 2 (C) 3 (D) -3

Ans. A

Sol. $\therefore (a, b, c) \equiv \left(-\frac{\lambda}{7}, -\frac{6\lambda}{7}, \lambda \right)$

$\therefore a = 2$ is given so $\lambda = -14$

$$\text{So } (a, b, c) \equiv (2, 12, -14)$$

So $\frac{3}{\omega^a} + \frac{1}{\omega^b} + \frac{3}{\omega^c} = -2$

62. Let $b = 6$, with a and c satisfying (E). If α and β are the roots of the quadratic equation $ax^2 + bx + c = 0$, then $\sum_{n=0}^{\infty} \left(\frac{1}{\alpha} + \frac{1}{\beta}\right)^n$, is

- (A) 6 (B) 7 (C) $\frac{6}{7}$ (D) ∞

Ans. B

Sol. $\therefore (a, b, c) \equiv \left(-\frac{\lambda}{7}, -\frac{6\lambda}{7}, \lambda\right)$

$\therefore b = 6$ so $\lambda = -7$.

So $(a, b, c) \equiv (1, 6, -7)$

So the equation $ax^2 + bx + c = 0$

$$x^2 + 6x - 7 = 0$$

So $\alpha = 1, \beta = -7$

$$S = \sum_{n=0}^{\infty} \left(\frac{1}{\alpha} + \frac{1}{\beta}\right)^n = \sum_{n=0}^{\infty} \left(\frac{1}{1} - \frac{1}{7}\right)^n$$

$$= \sum_{n=0}^{\infty} \left(\frac{6}{7}\right)^n = 1 + \frac{6}{7} + \left(\frac{6}{7}\right)^2 + \dots \dots \infty$$

$$= \frac{1}{1 - \frac{6}{7}} = 7$$

Section - IV (Total Marks : 28)

(Integer Answer Type)

This section contains **7 questions**. The angles to each of the questions is a single-digit integer, ranging from 0 to 9. The bubble corresponding to the correct answer is to be darkened in the ORS.

63. The minimum value of the sum of real numbers $a^{-5}, a^{-4}, 3a^{-3}, 1, a^8$ and a^{10} with $a > 0$ is

Ans. 8

Sol. A.M. \geq G.M.

$$\frac{a^{-5} + a^{-4} + a^{-3} + a^{-3} + a^{-3} + 1 + a^8 + a^{10}}{8} \geq (a^{-5} \cdot a^{-4} \cdot a^{-3} \cdot a^{-3} \cdot a^{-3} \cdot 1 \cdot a^8 \cdot a^{10})^{1/8}$$

$$a^{-5} + a^{-4} + a^{-3} + a^{-3} + a^{-3} + 1 + a^8 + a^{10} \geq 8$$

so minimum value is 8

64. Let $f(\theta) = \sin \left(\tan^{-1} \left(\frac{\sin \theta}{\sqrt{\cos 2\theta}} \right) \right)$ where $-\frac{\pi}{4} < \theta < \frac{\pi}{4}$. Then the value of $\frac{d}{d(\tan \theta)}(f(\theta))$, is :

Ans. [1]

Sol. $\therefore \tan\left(\frac{\sin\theta}{\sqrt{\cos 2\theta}}\right) = \sin^{-1} \tan \theta$

so $f(\theta) = \sin(\sin^{-1} \tan \theta) = \tan \theta$

$\therefore \frac{d(f(\theta))}{d(\tan \theta)} = \frac{d(\tan \theta)}{d(\tan \theta)} = 1$

65. If z is any complex number satisfying $|z - 3 - 2i| \leq 2$, then the minimum value of $|2z - 6 + 5i|$ is

Ans. 5

Sol.

So, Min of $|2z - 6 + 5i| = PA$

$= \text{Min } 2\left|z - 3 + \frac{5i}{2}\right| = 2 \times \frac{5}{2} = 5$

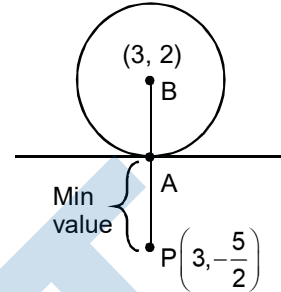

66. Let $f : [1, \infty) \rightarrow [2, \infty)$ be a differentiable function such that $f(1) = 2$. If $6 \int_1^x f(t) dt = 3x f(x) - x^3$

for all $x \geq 1$, then the value of $f(2)$ is

Ans. 6

Sol. $6 \int_1^x f(t) dt = 3x f(x) - x^3$

$6 f(x) = 3f(x) + 3x f'(x) - 3x^2$

$3f(x) = 3x f'(x) - 3x^2$

$3y = 3x \frac{dy}{dx} - 3x^2$

$x \frac{dy}{dx} - y = x^2$

$\frac{dy}{dx} - \frac{y}{x} = x$

I.F. = $e^{\int \frac{-1}{x} dx} = e^{-\ln x} = \frac{1}{x}$

$y \cdot \frac{1}{x} = \int x \cdot \frac{1}{x} dx \Rightarrow \frac{y}{x} = x + c \Rightarrow y = x^2 + cx$

$\therefore f(1) = 2 \Rightarrow c = 1$

$y = x^2 + x$

$f(2) = 4 + 2 = 6$

* The most appropriate answer to this question is (6), but because of ambiguity in language, IIT has declared this question as bonus (marks to all students)

67. The positive integer value of $n > 3$ satisfying the equation $\frac{1}{\sin \frac{\pi}{n}} = \frac{1}{\sin \frac{2\pi}{n}} + \frac{1}{\sin \frac{3\pi}{n}}$, is

Ans. 7

Sol. Let $\frac{\pi}{n} = \theta$

$$\frac{1}{\sin \theta} = \frac{1}{\sin 2\theta} + \frac{1}{\sin 3\theta}$$

$$\frac{1}{\sin \theta} - \frac{1}{\sin 3\theta} = \frac{1}{\sin 2\theta}$$

$$[\sin 3\theta - \sin \theta] \sin 2\theta = \sin \theta \sin 3\theta$$

$$2 \sin \theta \cos 2\theta \sin 2\theta = \sin \theta \sin 3\theta$$

$$\therefore \sin \theta \neq 0$$

$$2 \cos 2\theta \sin 2\theta = \sin 3\theta$$

$$\sin 4\theta = \sin 3\theta$$

$$\text{so either } 4\theta = 3\theta \text{ or } 4\theta = \pi - 3\theta$$

$$\text{so } \theta = 0 \text{ or } \theta = \pi/7 \text{ so } n = 7$$

68. Let $a_1, a_2, a_3, \dots, a_{100}$ be an arithmetic progression with $a_1 = 3$ and $S_p = \sum_{i=1}^p a_i$, $1 \leq p \leq 100$. For any integer n with $1 \leq n \leq 20$, let $m = 5n$. If $\frac{S_m}{S_n}$ does not depend on n , then a_2 is

Ans. 9 [Note: if common difference of A.P. is zero, then $a_2 = 3$ is also correct.]

Sol. $a_1 = 3$

$$\frac{S_m}{S_n} = \frac{S_{5n}}{S_n} = \frac{\frac{5n}{2} [2a_1 + (5n-1)d]}{\frac{n}{2} [2a_1 + (n-1)d]}$$

$$= \frac{5[(6-d) + 5nd]}{(6-d) + nd}$$

$$\therefore \frac{S_{5n}}{S_n} \text{ is independent of } n \text{ so } d = 6$$

$$\text{So } a_2 = a_1 + d = 3 + 6 = 9$$

* The most appropriate answer to this question is (9), but because of ambiguity in language, IIT has declared (3, 9 ; 3 & 9 both) as correct answer.

69. Consider the parabola $y^2 = 8x$. Let Δ_1 be the area of the triangle formed by the end points of its latus rectum and the point $P\left(\frac{1}{2}, 2\right)$ on the parabola, and Δ_2 be the area of the triangle formed by drawing tangents at P and at the end points of the latus rectum. Then $\frac{\Delta_1}{\Delta_2}$ is

Ans. 2

Sol. It is a property that area of triangle formed by joining three points lying on parabola is twice the area of triangle formed by tangents at these points

Alternate : $y^2 = 8x$

$$P\left(\frac{1}{2}, 2\right)$$

$$\Delta_1 = \frac{1}{2} |\text{Base} \times \text{Height}|$$

$$= \frac{1}{2} \times \frac{3}{2} \times 8 = 6$$

Also

Equation of tangent at $P\left(\frac{1}{2}, 2\right)$

$$y(2) = 4 \cdot \left(x + \frac{1}{2}\right)$$

$$y = 2x + 1 \quad \dots(1)$$

Tangent at A : $y = x + 2$

Tangent at B : $-y = x + 2 \Rightarrow y = -x - 2$

Point of intersection

$L(-2, 0), M(1, 3), N(-1, -1)$

$$\Delta_2 = \frac{1}{2} \begin{vmatrix} -2 & 0 & 1 \\ 1 & 3 & 1 \\ -1 & -1 & 1 \end{vmatrix}$$

$$= \frac{1}{2} [-2(4) + (-1+3)]$$

$$= \frac{1}{2} [-8 + 3 - 1] = 3$$

$$\text{So, } \frac{\Delta_1}{\Delta_2} = \frac{6}{3} = 2$$

